



Compact and Elegant

Completely enclosed sections provide improved aesthetic over 'open segment' umbilicals

Cable protection

Central stainless steel cord guarantees protection of cables from undue pressure or tension

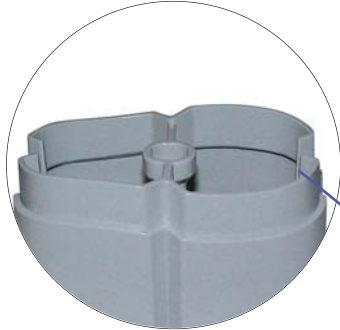

Segregated Sections

The unique design of the OE Elsafe Messenger incorporates two fully segregated compartments ensuring that data and power cabling are kept separate.

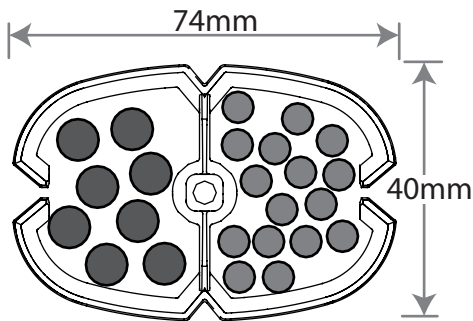

Cross section – Two compartment

1000mm² per compartment

Quick release button

A unique quick disconnect latch mechanism, that cannot be accidentally operated.



Press in Cover Plugs

4 press in screw cover plugs (2 plus 2 spares) are provided on the rear of the umbilical closure cap to complete a clean and crisp finish in the floor

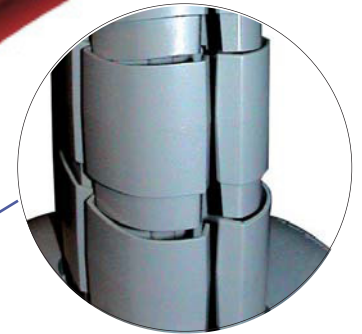

Ease of use

The interlocking jaws of each segment allow cables to be 'wiped-in' or removed easily at any time without the need to disassemble the umbilical



Messenger Grommet

For installation (80mm hole) in raised floors or floorbox lids the grommet provides a simple means of cable routing/protection through the floor.

The unique locking bridge allows the instant locking/unlocking of umbilicals to/from the floor – ensuring maximum protection to cables from undue stress.

Quickly installed with 'swing out clamps' and a wide flange, to cover the cut edge of the carpet, the grommet provides a neat and secure base fixing with an overall outside dimension of 125mm diameter.

UMBILICAL ACCESSORIES

Collar (White) - a smart through surfaces trim for ceiling, desk or 19" rack cabinet applications

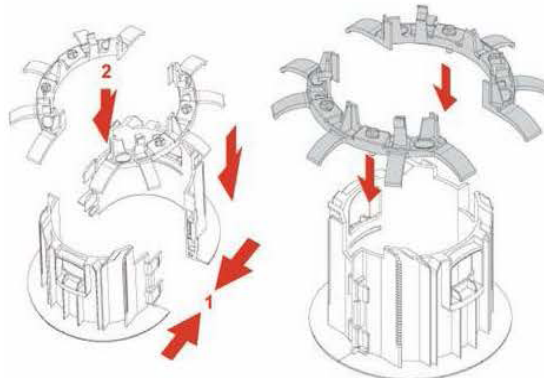
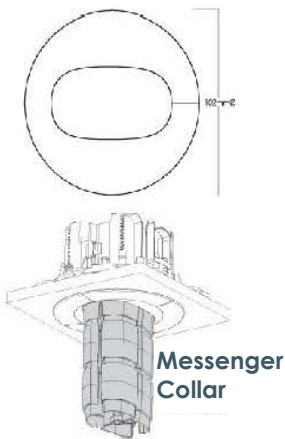

Collar installation procedure
(installed into a 102mm hole, from 2 - 40mm thick)

Terminations

Floor Grommet (Grey)
Through surface fixing

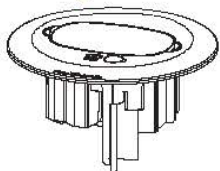

Weighted Base (Black)
Steel disc/Cast horseshoe

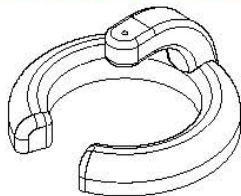

Gripper (CG2)
Screw down/up fixing

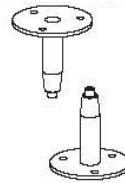

MPO (Grey)*
Surface mount fixing

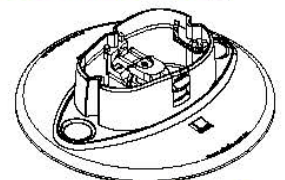

*Messenger Only

STANDARD UMBILICAL CONFIGURATIONS



loop to pin (C17)
Ideally suited for ceiling hung umbilicals either down to desk, screen or floor. The loop attaches to a hook/eyebolt allowing the wire to be pulled tight and/or length adjustable.

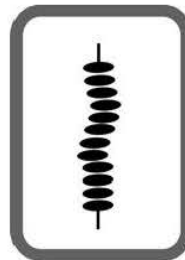

Pin to Pin (C21)
Predominantly for use between desk and floor - they are not length adjustable. Stocked in 750mm lengths, however special lengths can be made to suite eg: height adjustable desking.

Applications using loop to pin configurations



Gripper base (C15) - provides a fixed lower connection point to prevent movement of the umbilical and thereby ensure protection of the cables. Generally used in ceiling-floor or ceiling-screen applications.

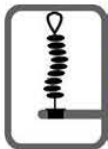

Collar base - a neat through desk solution with integral gripper allows cables to drop straight into the underdesk cable management, see illustration below far right.

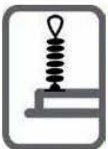

MPO base (Messenger only) - ideal as a seamless link into the top of workstation screens, completely enclosing the cables all the way into the screen, see right:

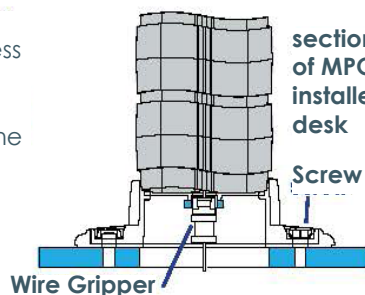

Applications using pin to pin configurations

Weighted base (C14) - simple solution to 'reduce' movement at the umbilical base. NB: Weighted bases provide limited stress protection for the cables and in this respect are unsuitable for ceiling hung applications.



Grommet base (C13) - provides total protection of cables into the floor. Ideal for raised floor applications, but also for installation directly into floor box lids - considerably increasing the cable exit capacity of a floorbox.

